

Electromagnetic flowmeters

Series FLOMAT



Insertion electromagnetic flowmeter for conductive liquids

- For use in large diameter pipes as an economical solution for flow measurement
- Flow rate measurement is independent of density, temperature, viscosity and pressure
- Pulsed coil excitation to obtain a minimum zero drift
- No moving parts involve low maintenance, low pressure drop and allow the pass of solids
- Low power consumption
- Good chemical resistance
- Flow rate: 2300 l/h ... 110000 m³/h
- Accuracy: $\pm 3.5\%$ reading value
- Minimum electric conductivity: 20 $\mu\text{S}/\text{cm}$
- Connections: inserted in pipes of DN40 ... DN2000, by means of:
 - TF Tecfluid standard flange
 - 2 1/4" BSP-F
 - DN40 PN16 EN 1092-1 flange
- Materials:
 - Sensor: EN 1.4404 (AISI 316L), PVDF
 - Sensor head: PVDF
 - Insert pipe adaptor: EN 1.4404 (AISI 316L), PE, PVC
Others on request
 - Electrodes: EN 1.4404 (AISI 316L), Hastelloy C, Tantalum, Titanium, Zirconium
- Local indication, volume totalizer, 4-20 mA and pulse outputs
- Alarms, empty pipe detection, etc. depending on converter model
- Full diagnosis for MX4 converter
- HART and Modbus Communication protocols available on request
- Modular design in two versions:
 - Compact converter, mounted on top of the sensor
 - Remote converter for wall or pipe mounting



HART
COMMUNICATION PROTOCOL

Modbus

Working principle

The measurement principle is based on Faraday's induction law. A voltage V is induced between a pair of electrodes when a conductive liquid flows in a pipe of diameter D at an average velocity v , through a magnetic field B (which is perpendicular to the flow direction).

This voltage, proportional to the average velocity of the liquid, is acquired by the electronic converter in order to be processed and converted to a flow rate measurement.

$$V = B \cdot v \cdot D$$

V = Voltage across the electrodes

v = Liquid velocity

B = Magnetic field strength

D = Pipe diameter

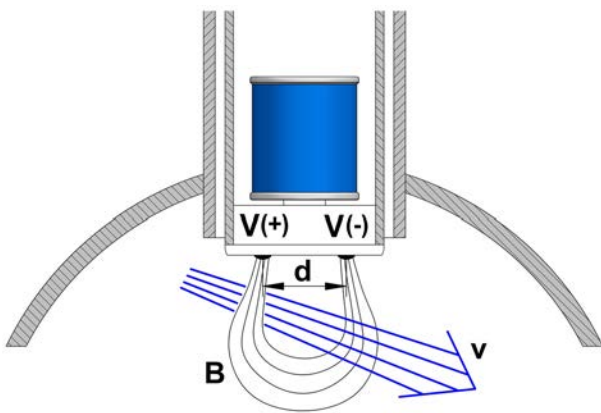

Applications

- Water supply & water treatment plants
- Food and beverage industries
- Leak detection in pipelines & chemicals flow monitoring
- HVAC

Technical data

- **Accuracy:** $\pm 3.5\%$ reading value for flow speed ≥ 0.4 m/s
- **Minimum electric conductivity:** 20 $\mu\text{S/cm}$
- **Liquid temperature:** $-20^\circ\text{C} \dots +120^\circ\text{C}$
- **Ambient temperature:** $-20^\circ\text{C} \dots +60^\circ\text{C}$
- **Working pressure:** PN16. Others on request
- **Connections:** inserted in pipes of DN40 ... DN2000, by means of:
 - TF Tecfluid standard flange
 - 2 1/4" BSP-F
 - DN40 PN16 EN 1092-1 flange
- **Materials:**
 - Sensor: EN 1.4404 (AISI 316L), PVDF
 - Sensor head: PVDF
 - Insert pipe adaptor: EN 1.4404 (AISI 316L), PVC, PE Others on request
 - Electrodes: EN 1.4404 (AISI 316L), Hastelloy C, Tantalum, Titanium, Zirconium

- **Local indication, volume totalizer, 4-20 mA and pulse outputs**
- **Alarms, empty pipe detection, etc. depending on converter model**
- **Full diagnosis** for MX4 converter
- **HART** (MX4H & XT5H converters) and **Modbus** (MX4B converter) communication protocols available on request
- **Modular design** in two versions:
 - Compact converter (MX4 or XT5), mounted on top of the sensor
 - Remote converter (MX4M or XT5M) for wall or pipe mounting

Installation

- Sensor must not be installed in the upper or lower parts of the pipe, in order to avoid air bubbles or solids sedimentation.

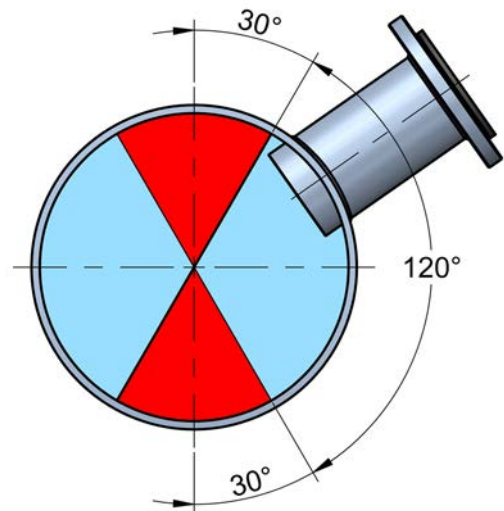

- Pipe must always be full of liquid.
- Required straight pipe run depends on the flow profile, which can be affected by the disturbing elements found in the installation before and after the sensor, as shown in the following chart:

Disturbing element before the sensor	Minimum distance between the element and the sensor
90° elbow or T-bend	50 x DN
Several 90° coplanar bends	50 x DN
Several 90° non-coplanar bends	80 x DN
Total angle convergent 18° to 36°	30 x DN
Total angle divergent 14° to 28°	55 x DN
Fully opened butterfly valve	45 x DN
Fully opened plug valve	30 x DN

After the sensor a minimum straight pipe run of 5 x DN is required.

Electromagnetic flowmeters

Series FLOMAT

Models

In case of metallic or plastic pipe where Tecfluid insert pipe adaptor can be supplied (see p. 2), installation can be made by welding or gluing the adaptor as follows:

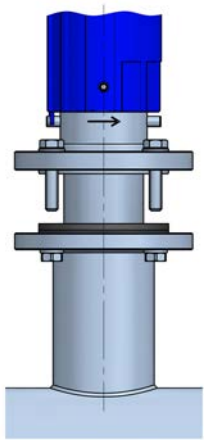

FLOMAT-FX2
flanged connection

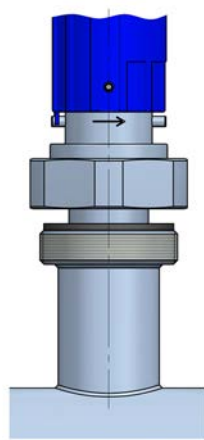

FLOMAT-FX1
threaded connection



In those cases where Tecfluid insert pipe adaptor cannot be used (FRP or similar pipes), installation should be made by means of a CLAMP-ON saddle (not supplied):

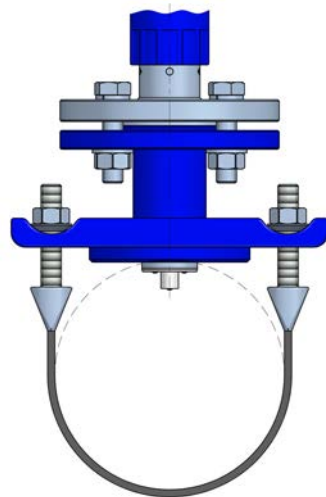

CLAMP-ON saddle
for non-metallic pipes

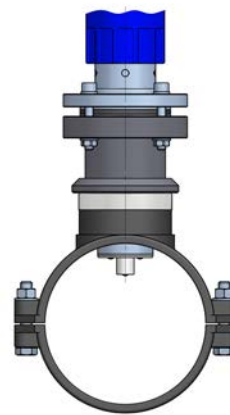

CLAMP-ON saddle
for plastic pipes

Materials

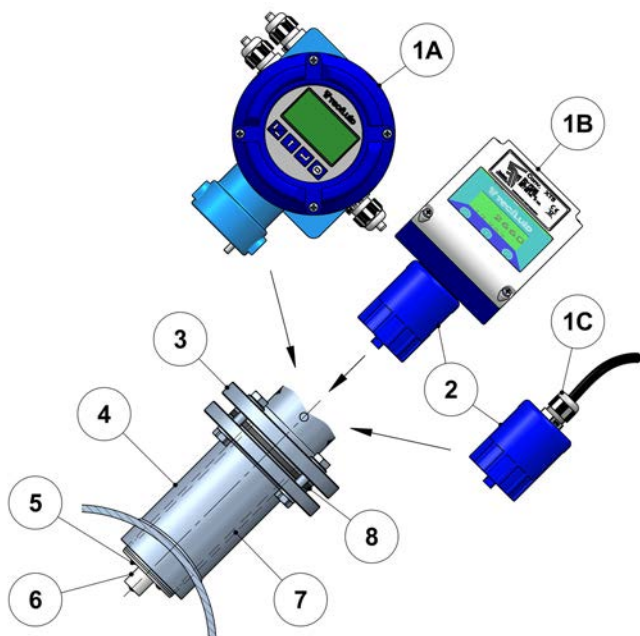

N°	Description	Materials
1A	MX4 housing	Aluminium
1B	XT5 housing	Polycarbonate
1C	Packing gland	Polyamide
2	Connector	Polycarbonate *
3	Flange / BSP nut	EN 1.4404 (AISI 316L)
4	Insert pipe adaptor	EN 1.4404 (AISI 316L), PVC, PE **
5	Electrodes	EN 1.4404 (AISI 316L), Hastelloy C, Titanium, Tantalum, Zirconium
6	Head	PVDF
7	Sensor body	EN 1.4404 (AISI 316L), PVDF
8	Gasket	NBR, VITON®

* Also available in EN 1.4404 (AISI 316L) on request

** Others on request

Dimensions

Sensor

DN	A	FX *	FM *	FR *
40...400	113,5	340	327	240
500...1000	218,5	445	432	345
1200...2000	368,5	595	582	495

* minimum dimension to remove the flowmeter from the pipe

Insert pipe adaptor

There are two different types of insert pipe adaptors. For pipe size DN40 ... DN65, insert pipe adaptor is supplied already welded to short length of pipe that must be just coupled to the pipe by welding or gluing (in the case of PVC).

For pipe size of DN80 or bigger, insert pipe adaptor is directly welded (or glued) on the pipe.

DN	C (mm)	Insert pipe adaptor		
		L (mm)	H (mm)	
80	10,0	93	88,0 - s	
100	12,5		85,5 - s	
125	15,5		82,5 - s	
150	19,0		79,0 - s	
200	25,0		73,0 - s	
250	31,0		67,0 - s	
300	37,5		60,5 - s	
350	44,0		54,0 - s	
400	50,0		48,0 - s	
500	62,5		145	140,5 - s
600	75,0	128,0 - s		
700	87,5	115,5 - s		
800	100,0	103,0 - s		
900	112,5	90,5 - s		
1000	125,0	78,0 - s		
1200	150,0	203,0 - s		
1400	175,0	178,0 - s		
1600	200,0	205		153,0 - s
1800	225,0	128,0 - s		
2000	250,0	103,0 - s		

s: pipe thickness (depends on pipe material and pressure rating)
C: penetration depth

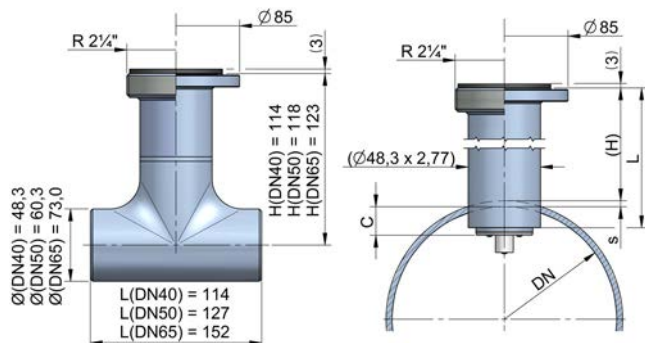

Sensor with compact converter

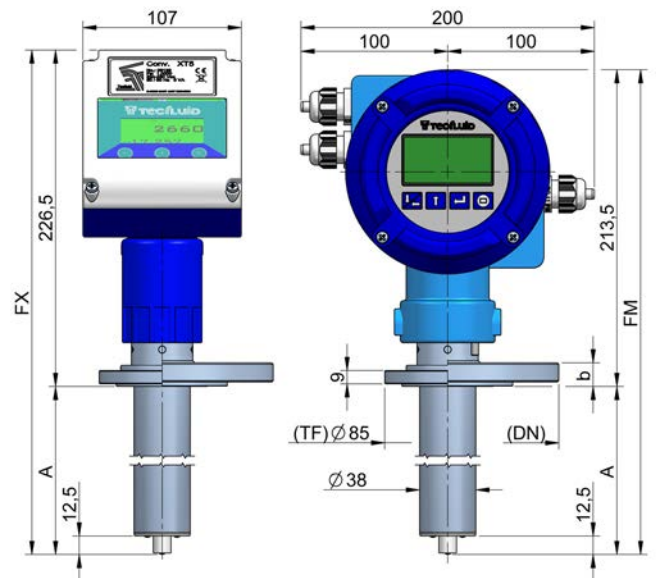
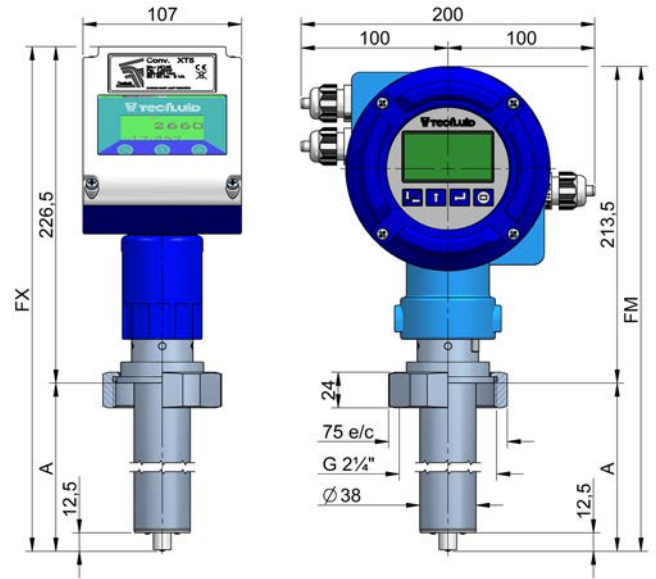

Sensor with remote converter (IP68 10 m H₂O)

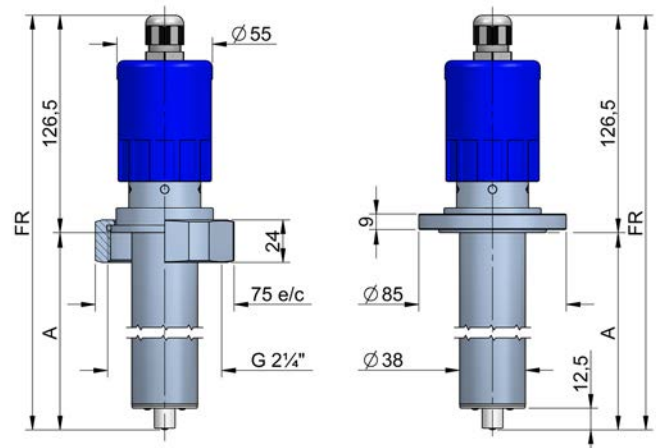

Flow ranges

Sensor selection

The diagram shows the correspondance between the liquid velocity and the flow rate for different sensor sizes.

The sensor size should be chosen selecting a liquid velocity of about 3-4 m/s. The minimum liquid velocity should not be below 0.5 m/s.

When the liquid has solids in suspension, it is better to work between 3 and 5 m/s in order to avoid sedimentation in the pipe and sensor.

Accuracy curve (error vs velocity)

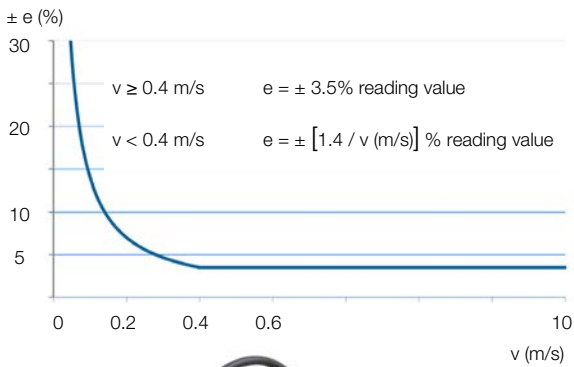

FLOMAT-FX1 with remote XT5M converter



FLOMAT-FX2 with CLAMP-ON saddle for non-metallic pipes and compact XT5 converter with AISI 316L connector

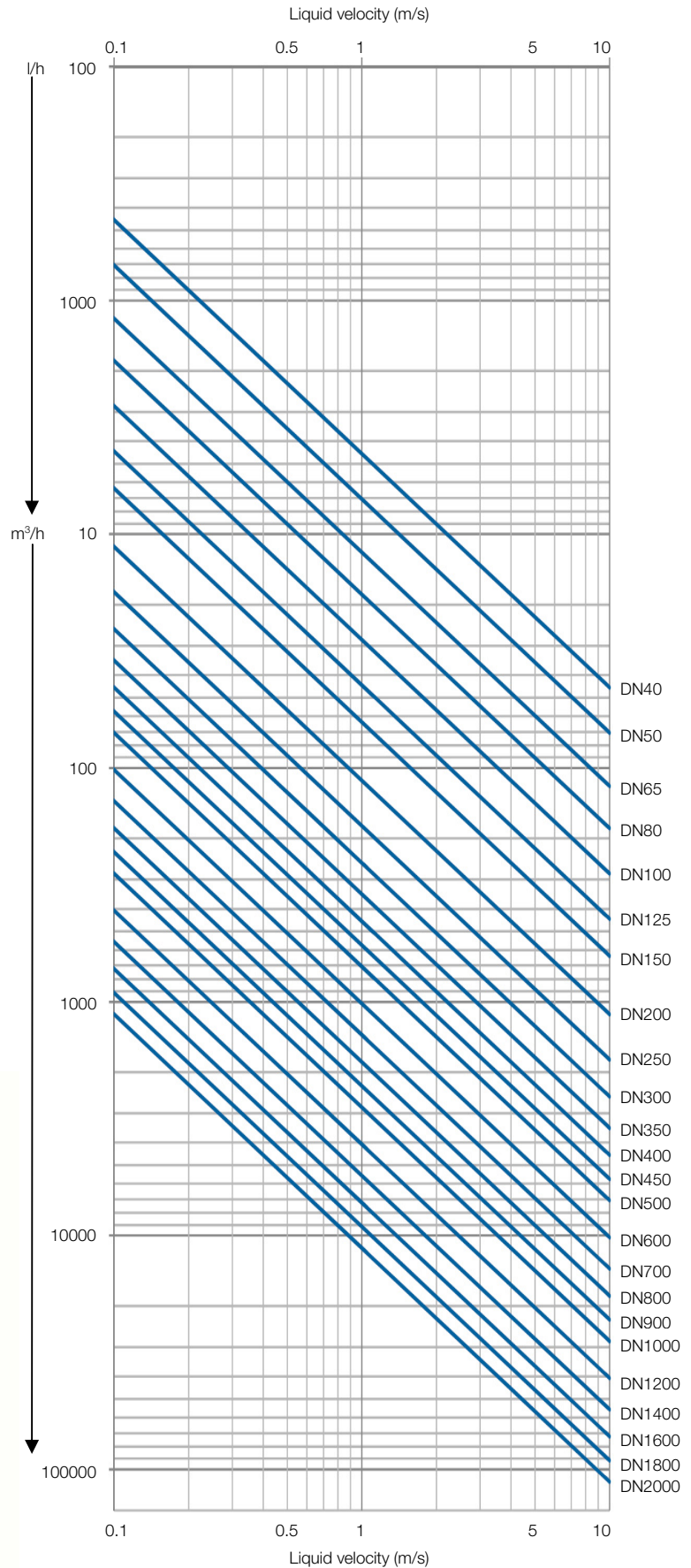

Electronic converters

Different models of electronic control units are available to comply with the options of flow indication, maximum / minimum flow rate control, analog and pulse outputs.

All of them are compatible with the different FLOMAT-FX sensor models.

These converters can be supplied for compact mounting directly on top of the sensor or for remote mounting. Cable is supplied.

HART protocol is available for both MX4 and XT5 converters.

Modbus RTU protocol is available for MX4 converter.

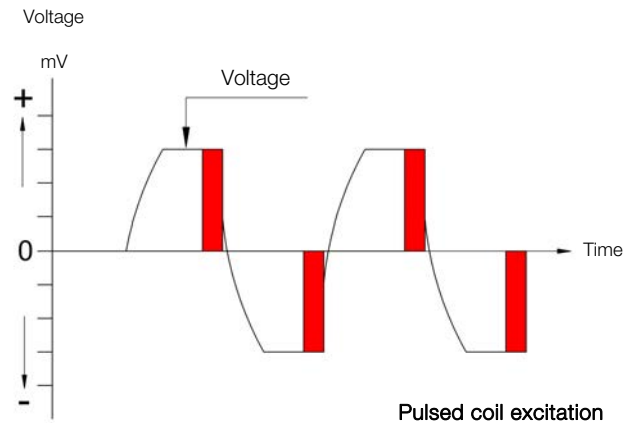

XT5 converter

Technical data

- IP67 polycarbonate enclosure
- Programming via front tactile push buttons
- Linearity: $\pm 0.2\%$ f.s.
- Repeatability: $\pm 0.1\%$ f.s.
- Ambient temperature range: $0^{\circ}\text{C} \dots +60^{\circ}\text{C}$
- Power supply: 24, 115, 230, 240 VAC 50 / 60 Hz
24 VDC
- Power consumption: ≤ 5 VA
- Flow rate indication:
 - No. of digits: 4 (0 to 2 decimal configuration)
 - Digit size: 5 mm
- Volume totalizer:
 - No. of digits: 7 (2 decimal)
 - Digit size: 8 mm
 - Reset button
- Analog output: 4-20 mA, active or passive, programmable measuring units
- Pulse output: optoisolated:
 - V_{max} : 30 VDC ; I_{max} : 30 mA
 - Maximum frequency in "P/U" mode: 6.25 Hz
 - Frequency in "Hz" mode: 0.04 ... 5000 Hz
- Empty pipe detection
- Flow rate cut off, programmable
- Adaptive flow rate filter: programmable integration time between 0.1 ... 20 seconds
- Zero offset adjustment



Remote mounted converter (model XT5M)

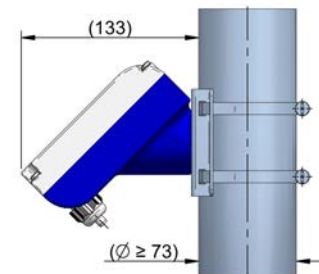
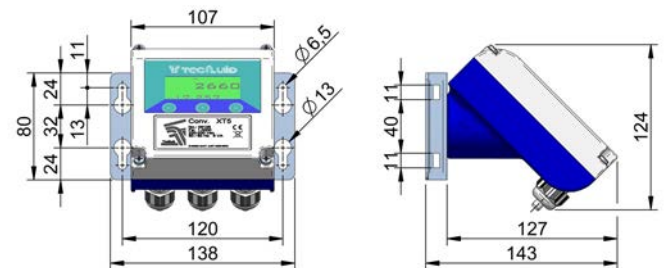

Weight XT5: 700 g

XT5 compact converter



XT5M remote converter



HART Communication protocol

XT5H converter has a modem for HART communication. All the features regarding HART communication can be found in the corresponding document "Field Device Specification". Compatible with HART Server Communication software.

Also available for remote mounted version XT5HM.

Electromagnetic flowmeters

Series FLOMAT

MX4 converter



Technical data

- IP67 coated aluminium enclosure
- Programming via front push buttons
- 128 x 64 graphic display
- Linearity: $\pm 0.2\%$ f.s.
- Repeatability: $\pm 0.1\%$ f.s.
- Ambient temperature range: $-20^{\circ}\text{C} \dots +60^{\circ}\text{C}$
- Power supply: 90 ... 265 VAC 50 / 60 Hz
12 ... 48 VDC
- Power consumption: ≤ 5 VA
- Flow rate and liquid velocity indication:
 - No. of digits: 5 (0 to 2 decimal configuration)
 - Digit size: 11 mm
- Volume totalizer:
 - No. of digits: 8 (2 decimal)
 - Digit size: 8 mm
 - Reset button
- Analog output: 4-20 mA, active or passive, programmable measuring units
- Pulse output: optoisolated NPN bipolar transistor:
 - V_{max} : 30 VDC ; I_{max} : 30 mA
 - Output frequency: 0.01 ... 5000 Hz
 - Programmable duty cycle
- Relay outputs: 2 relays with potential free contacts.
 - Contact characteristics:
 - Maximum voltage: 250 VAC
 - Maximum current: 8 A
 - Maximum power: 500 VA

Programmable as flow rate alarms, empty pipe detection or reversed flow indication

- Empty pipe detection
- Flow rate cut off, programmable
- Adaptive flow rate filter: programmable integration time between 0 ... 40 seconds
- Zero offset adjustment
- Full diagnosis of the coil current, the differential voltage on the sensor electrodes and the conductivity of the liquid, as well as detection of an electronic failure in the measuring circuit
- Easy programmable by means of Tecfluid's Winsmeter MX4 software, available for download at www.tecfluid.com

HART and Modbus RTU RS485 Communication protocols

MX4B converter includes a Modbus RTU RS485 Communication protocol module.

MX4H converter has a modem for HART communication. All the features regarding HART communication can be found in the corresponding document "Field Device Specification". Compatible with HART Server Communication software.

Also available for remote mounted versions MX4BM & MX4HM.

Remote mounted converter (model MX4M)

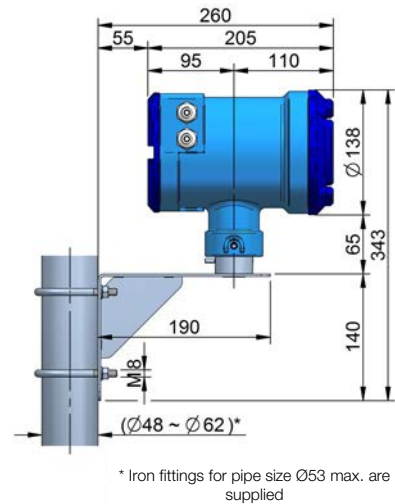
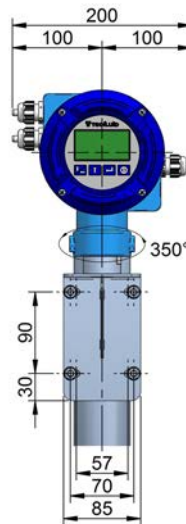
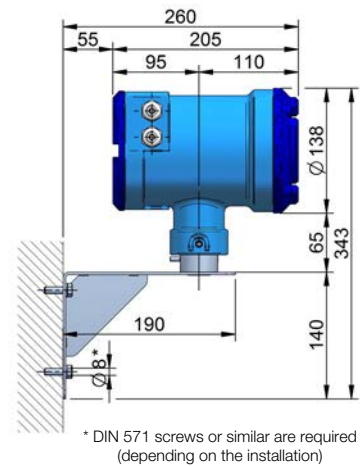
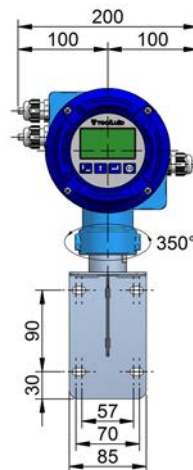

Weight MX4: 3.3 kg



FLOMAT-FX1 with compact MX4 converter
Installation example

Accessories

FLOMAT-TAP

The FLOMAT-TAP accessory is a useful complement for the FLOMAT sensors in some type of installations.

The key features of the product are:

- FLOMAT sensors can be inserted or removed under pressure (pipe full of liquid).
- Designed for obtaining flow measurement in different points of a distribution network with only one FLOMAT sensor.

FLOMAT-TAP dimensions

DN	A	B
100 ... 600	750	420
700 ... 1200	865	535
1300 ... 2000	990	660

DN	C (mm)	M-TAP insert pipe adaptor	
		LT (mm)	HT (mm)
100	12.5	365	357.0 - s
125	15.5		354.0 - s
150	19.0		350.5 - s
200	25.0		344.5 - s
250	31.0		338.5 - s
300	37.5		332.0 - s
350	44.0		325.5 - s
400	50.0		319.5 - s
500	62.5		307.0 - s
600	75.0		294.5 - s
700	87.5	450	377.0 - s
800	100.0		364.5 - s
900	112.5		352.0 - s
1000	125.0		339.5 - s
1200	150.0		314.5 - s
1400	175.0		414.5 - s
1600	200.0		389.5 - s
1800	225.0		364.5 - s
2000	250.0		339.5 - s
			575

- Maintenance of FLOMAT sensors without interruption of the flow.

The M-TAP accessory must be installed to the main pipe as an insert pipe adaptor and it is a part of the complete system FLOMAT-TAP.

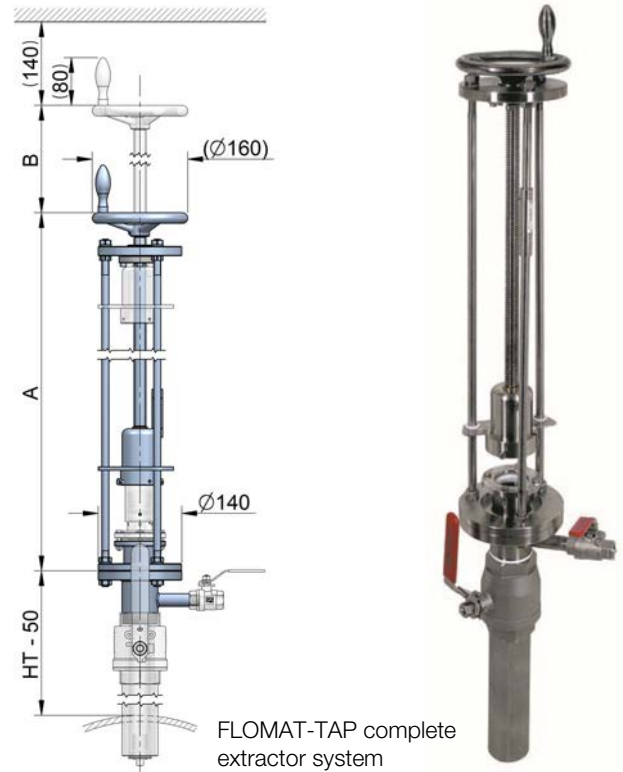

FLOMAT-TAP complete extractor system

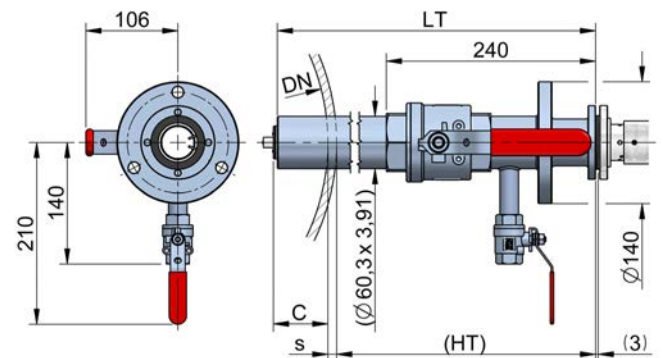

M-TAP insert pipe adaptor



Tecfluid S.A.

Narcis Monturiol 33
08960 Sant Just Desvern
Barcelona
Tel: +34 93 372 45 11
Fax: +34 93 473 44 49
tecfluid@tecfluid.com
www.tecfluid.com

Quality Management System ISO 9001 certified by **Applus[®]**

Pressure Equipment Directive 97/23/CE certified by **Lloyd's Register**

ATEX European Directive 94/9/CE certified by **LOM**

HART[®] is a registered trademark of HART Communication Foundation