

Primary characteristics

NAF-Triball is a full bore ball valve designed for shut-off, on-off functions as well as control application for the metal seated version. The ball valve is made of stainless steel with maximum pressure of 40 bar(e) and in sizes DN 10-100.

NAF-Triball has

- 3-piece body, which simplifies disassembling
- floating ball which makes the valve tight in both directions even at low pressure
- the stem is provided with an axial bearing washer of PTFE which seals off the media from the packing gland
- packing gland of PTFE that can be tightened, if necessary, and O-ring of FPM
- soft seated or metal seated
- lockable handlever in open or closed position
- valve top according to ISO 5211

CE-marked according to Pressure Equipment Directive (PED 97/23/EG) module H, category III.
For module H1, category IV contact NAF

Applications

NAF-Triball can be used as a control valve (metal seated) or as a shut-off valve, in a wide variety of applications and in different operating modes. The soft seat version should only be used in the full open or full closed position to avoid deformation of the seat rings.

One model, NAF 8886x4 can be used for sampling, for example suspended media where the risk is high for valve plugging. In this version the valve is fitted with a special end piece with the same radius as the connected pipework. The valve can be welded to the piping, which enables the ball to be closer to the media, which virtually eliminates any plugging.



Working pressure, differential pressure and temperatures

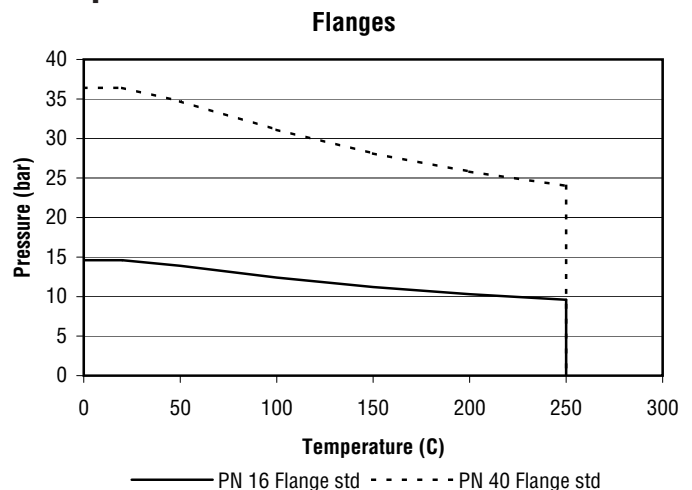

*) Flange std according to EN-1092-1:2001

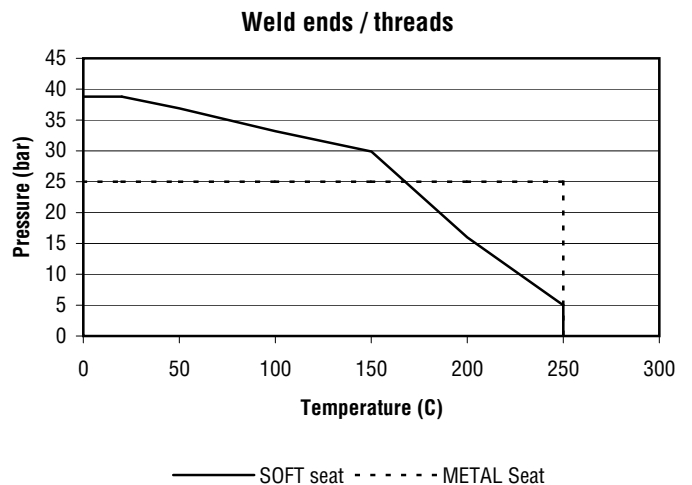

Technical specification	
Material:	Stainless steel
Dimension range:	DN10-100
Pressure class:	PN10-40
Temperature range:	-30 till 250°C
Test pressure	
Open valve:	1,5 x max. working pressure
Closed valve:	1,1 x max. differential pressure
Sealing class	
Soft seats:	EN 12266-1, Rate A
Metal seats:	SS-IEC 534-4, Class V Testing medium water

Valve types



NAF 888650/60
DN 10-100
Female cylindrical,
pipe thread Rp.



NAF 888655/65
DN 10-100
Long welding end mm and
female cylindrical, pipe
thread Rp.



NAF 888651/61
DN 10-100
Short welding ends
for "mm" pipes



NAF 888656/66
DN 10-80
Female pipe thread NPT

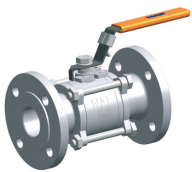

NAF 888652/62
DN 15-65, PN 10-40
NAF 888352/62
DN 80-100, PN10-16
Face-to-face length acc. to
DIN 3202-F1 and ISO 5752
serie 1 Flanges

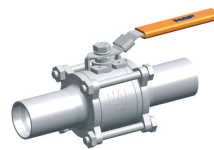

NAF 888657/67
DN 10-100
Long welding ends for ISO
pipes acc. to ISO 4200 range E

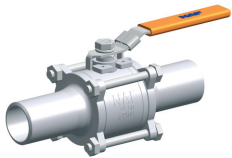

NAF 888653/63
DN 10-100
Long welding ends for
"mm" pipes



NAF 888658/68
DN 15-65, PN 10-40
Flanges and female cylindrical
pipe thread Rp.



NAF 888654/64
DN 15-25, 40-50 and 80-100
Welding end for "mm" pipe
and connection plate for
sampling.
Consult NAF for more
information.



NAF 888659/69
DN 10-100
Long welding end for ISO pipe
acc. to ISO 4200 and female
cyl. pipe thread Rp.

**Dimensions of ISO 5211 mounting flange and stem
(Table 1)**

DN	10	15	20	25	32	40	50	65	80	100
A	3/8	7/16	7/16	5/8	5/8	5/8	5/8	3/4	3/4	3/4
	UNF	UNF	UNF	UNF	UNF	UNF	UNF	UNC	UNC	UNC
B	6	6.5	6.5	9.5	9.5	9.5	9.5	12	12	15
C	9.5	11.5	11.5	15.9	15.9	15.9	15.9	19	19	21.9
E	9	12.2	12.2	14	14	13.5	13.5	24.1	24.1	29.4
F	14	21	21	26	26	28	28	43	43	44
G	1.8	1.8	1.8	2.5	2.5	4	4	5.5	5.5	1
H	39	49.6	53.3	66.2	72.2	80	87.9	119.2	129.8	145.3
J				35	35	35	35	55	55	70
K	36	36	36	50	50	50	50	70	70	102
M	M5	M5	M5	M6	M6	M6	M6	M8	M8	M10
N	3	4	5.3	9	9	10	10	13	13	15
O	3	4	5.3	6.5	6.5	6.5	6.5	10	10	12
*	F03	F03	F03	F05	F05	F05	F05	F07	F07	F10

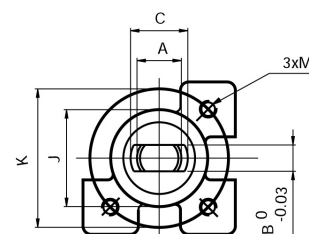
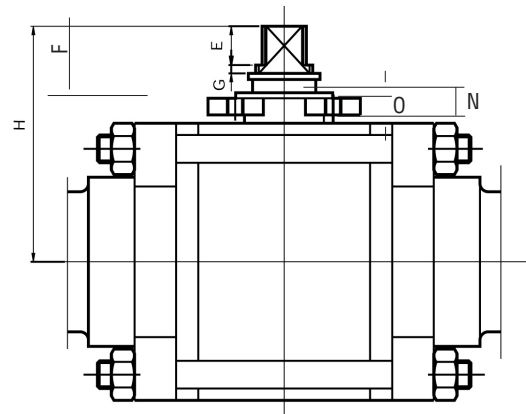

* ISO - 5211

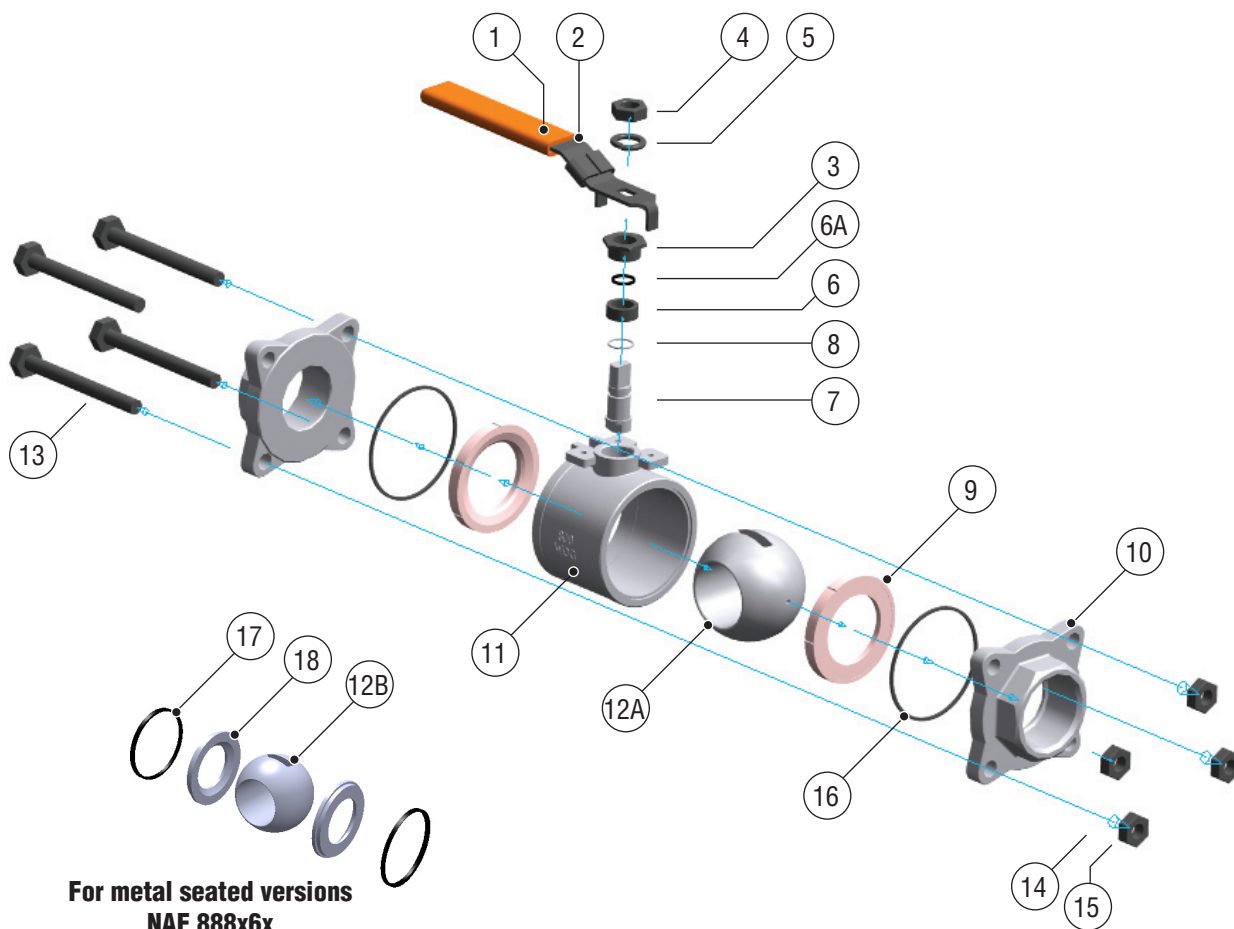

Materials (Table 2)

Item	Part	Material	Recommended spare parts
1	Sleeve	PVC	
2	Lever	EN1.4301	
3	Gland, DN < 50 Gland, DN > 65	EN1.4435 EN1.4301	
4	Nut	A2	
5	Washer	EN1.4301	
6	Boxpacking	PTFE	A
6 A	O-ring	FPM	A
7	Stem	EN1.4435	
8	Bearing washer	PTFE	A
9	Seat ring + body seal ring	Reinforced PTFE	B
10	End piece	EN1.4408	
11	Body	EN1.4408	
12 A	Ball	EN1.4435	
12 B	Ball, EN plated	EN1.4435, EN-plated	C
13	Hex. screw, DN < 50 Stud, DN > 65	A2 A2	
14	Spring washer	EN1.4301	
15	Nut	A2	
16	Seal ring	PTFE	B, C
17	Seal ring	R-PTFE carbon reinforced	C
18	Seat ring	SS / Alloy 6	C

Spare part kits

- A – Box packing kit
- B – Seat ring kit (for soft seated versions NAF 888x5x)
- C – Ball combo kit (for metal seated versions NAF 888x6x)

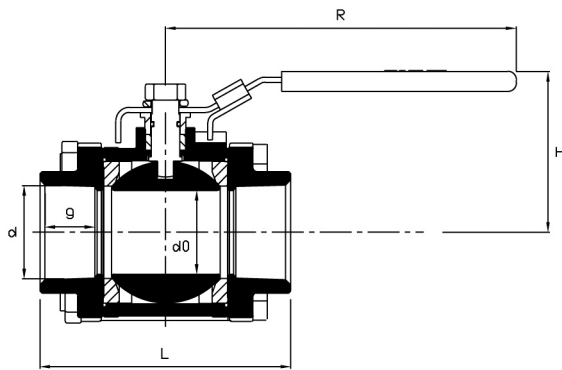

NAF 888650 / 60 (Table 3)

DN	d0	d	g	L	H	R	Kg
10	12.7	R 3/8"	10	64	48	96	0.4
15	15.9	R 1/2"	15.5	74	54	124	0.7
20	20.6	R 3/4"	17	86	57	124	1.0
25	25.4	R 1"	19	98	64	142	1.4
32	31.8	R 1 1/4"	23	122	70	142	2.3
40	38.1	R 1 1/2"	23	136	86	202	3.4
50	50.8	R 2"	23	154	93	202	5.6
65	63.0	R 2 1/2"	25	173	139	250	8.5
80	76.0	R 3"	28	193	150	250	13.0
100	95.0	R 4"	32	216	160	300	20.5

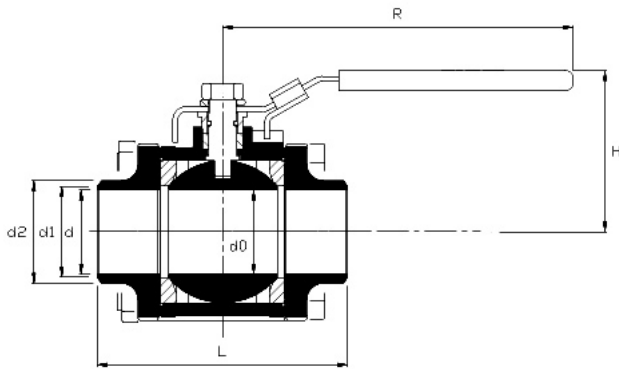

NAF 888651 / 61 (Table 4)

DN	d0	d	d1	d2	L	H	R	Kg
10	12.7	10	12	18	64	48	96	0.4
15	15.9	15	17	22	74	54	124	0.7
20	20.6	20	22	28	86	57	124	1.0
25	25.4	25	28	34	98	64	142	1.4
32	31.8	32	35	43	122	70	142	2.3
40	38.1	40	43	49	136	86	202	3.4
50	50.8	50	54	61	154	93	202	5.6
65	63.0	65	69	78	173	139	250	8.5
80	76.0	80	84	100	193	150	250	13.0
100	95.0	100	105	125	216	160	300	20.5

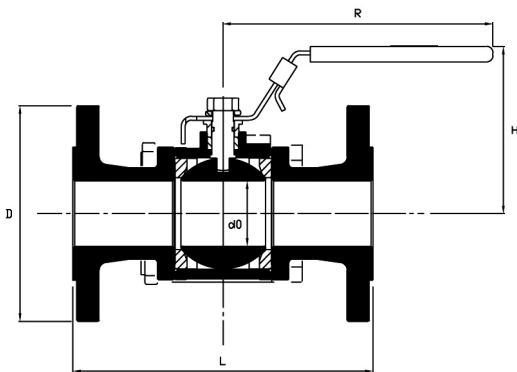

NAF 888652 / 62, 888352 / 62 (Table 5)

DN	Flanges	d0	D	L	H	R	Kg
15	PN 40	15.9	95	130	86	124	2.3
20	"	20.6	105	130	86	124	3.2
25	"	25.4	115	160	80	142	4.2
32	"	31.8	140	180	100	142	5.1
40	"	38.1	150	200	100	202	7.4
50	"	50.8	165	230	110	202	10.0
65	"	69.0	185	290	139	250	15.4
80	PN16	76.0	200	310	150	250	24.0
100	"	95.0	220	350	160	300	34.0

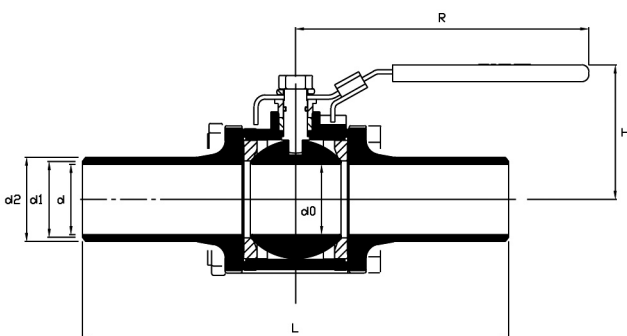

NAF 888653 / 63 (Table 6)

DN	d0	d	d1	d2	L	H	R	Kg
10	12.7	10	12	17	214	48	96	0.6
15	15.9	15	17	21	224	54	124	0.9
20	20.6	20	22	27	236	57	124	1.2
25	25.4	25	28	33	248	64	142	1.6
32	31.8	32	35	42	272	70	142	2.5
40	38.1	40	43	49	286	86	202	3.8
50	50.8	50	54	60	304	93	202	6.3
65	63.0	65	69	76	323	139	250	10.0
80	76.0	80	84	91	343	150	250	14.5
100	95.0	100	105	114	366	160	300	24.0

NAF 888654 / 64 (Table 7)

DN	d0	d	d1	d2	L	L1	H	R	Kg
15	15.9	15.9	17	21	112	33	54	124	1.9
20	20.6	20.6	22	27	118	37	57	124	2.7
25	25.4	25	28	34	124	42	64	142	3.6
40	38.1	40	43	49	143	53	86	202	6.3
50	50.8	50	54	61	152	67	93	202	8.5
80	76	76	84	91	172	94	150	250	20.4
100	95	95	105	114	183	100	160	300	28.9

Dy = pipe dimension
* For dimensions, see Fi25.622

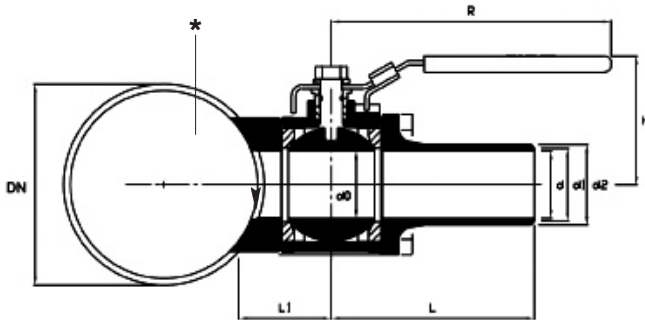

Selection table for connection plate (Table 8)

-	Pipe	DN						
		80-100	125	150-200	250	300-400	450-600	=> 700
Flanges	-	-	-	-	-	-	-	-
DN25	-	A	B	B	C	C	0	0
DN50	-	-	-	B	C	C	D	0
DN80	-	-	-	-	C	C	D	0
DN100	-	-	-	-	-	C	D	0

Other valve sizes only in version O and Z
Product code, see page 8 position 6.

NAF 888655 / 65 (Table 9)

DN	d0	da	g	db	d1	d2	L	H	R	Kg
10	12.7	R 3/8"	10	10	12	17	139	48	96	0.5
15	15.9	R 1/2"	15.5	15	17	21	149	54	124	0.8
20	20.6	R 3/4"	17	20	22	27	161	57	124	1.1
25	25.4	R 1"	19	25	28	33	173	64	142	1.5
32	31.8	R 1 1/4"	23	32	35	42	197	70	142	2.4
40	38.1	R 1 1/2"	23	40	43	49	211	86	202	3.6
50	50.8	R 2"	23	50	54	60	229	93	202	5.9
65	63.0	R 2 1/2"	25	65	69	76	248	139	250	9.2
80	76.0	R 3"	28	80	84	91	268	150	250	13.0
100	95.0	R 4"	32	100	105	114	291	160	300	22.3

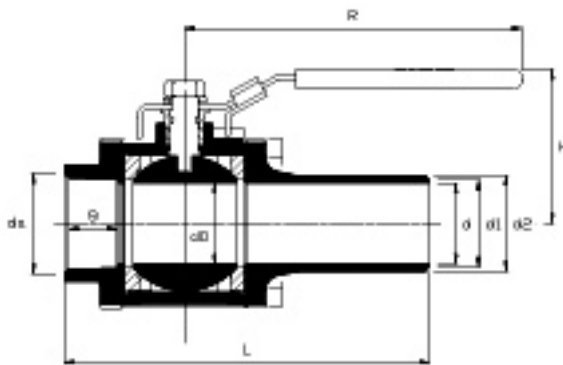

NAF 888656 / 66 (Table 10)

DN	d0	d	g	L	H	R	Kg
10	12.7	NPT 3/8"	10	64	48	96	0.4
15	15.9	NPT 1/2"	15.5	74	54	124	0.7
20	20.6	NPT 3/4"	17	86	57	124	1.0
25	25.4	NPT 1"	19	98	64	142	1.4
32	31.8	NPT 1 1/4"	23	122	70	142	2.3
40	38.1	NPT 1 1/2"	23	136	86	202	3.4
50	50.8	NPT 2"	23	154	93	202	5.6
65	63.0	NPT 2 1/2"	25	173	139	250	8.5
80	76.0	NPT 3"	28	193	150	250	13.0

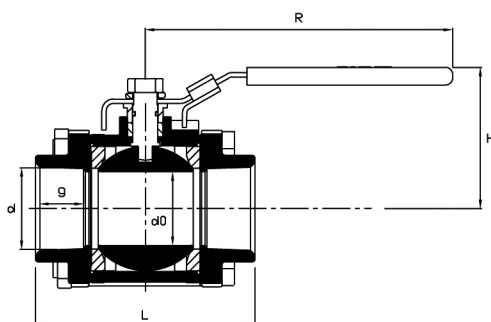

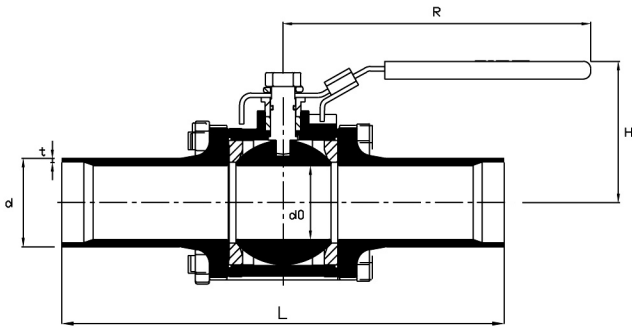

NAF 888657 / 67 (Table 11)

DN	d0	d	t	L	H	R	Kg
10	12.7	17.2	2.0	214	48	96	0.6
15	15.9	21.3	2.0	224	54	124	0.9
20	20.6	26.9	2.0	236	57	124	1.2
25	25.4	33.7	2.3	248	64	142	1.6
32	31.8	42.4	2.6	272	70	142	2.5
40	38.1	48.3	2.6	286	86	202	3.5
50	50.8	60.3	2.9	304	93	202	5.0
65	63.0	76.1	2.9	323	139	250	10.0
80	76.0	88.9	3.2	343	150	250	14.0
100	95.0	114.3	3.6	366	160	300	24.0

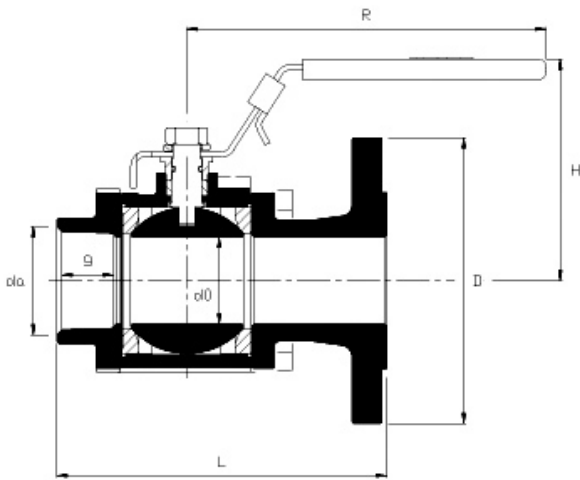

NAF 888658 / 68 (Table 12)

DN	Flanges	d0	d	g	L	H	R	Kg
15	PN 40	15.9	R 1/2"	15.5	102	86	124	2.3
20	"	20.6	R 3/4"	17	108	86	124	3.2
25	"	25.4	R 1"	19	129	80	142	4.2
32	"	31.8	R 1 1/4"	23	151	100	142	5.1
40	"	38.1	R 1 1/2"	23	168	100	202	7.4
50	"	50.8	R 2"	23	192	110	202	10.0
65	"	63.0	R 2 1/2"	25	232	139	250	15.4

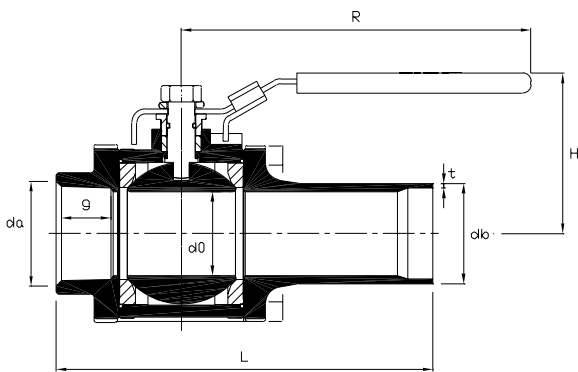

NAF 888659 / 69 (Table 13)

DN	d0	da	g	db	t	L	H	R	Kg
10	12.7	R 3/8"	10	17.2	2.0	139	48	96	0.5
15	15.9	R 1/2"	15.5	21.3	2.0	149	54	124	0.8
20	20.6	R 3/4"	17	26.9	2.0	161	57	124	1.1
25	25.4	R 1"	19	33.7	2.3	173	64	142	1.5
32	31.8	R 1 1/4"	23	42.4	2.6	197	70	142	2.4
40	38.1	R 1 1/2"	23	48.3	2.6	211	86	202	3.6
50	50.8	R 2"	23	60.3	2.9	229	93	202	5.9
65	63.0	R 2 1/2"	25	76.1	2.9	248	139	250	9.2
80	76.0	R 3"	28	88.9	3.2	268	150	250	13.0
100	95.0	R 4"	32	114.3	3.6	291	160	300	22.3

Capacity and operating torque (Table 14)

Torque (Nm) - differential pressure - soft sealing						
DN	Dp (bar)					
	5	10	15	20	25	40
10	5	5	6	6	7	7
15	6	7	7	7	8	9
20	10	10	11	12	13	14
25	14	14	14	14	14	21
32	22	24	26	27	31	34
40	25	27	29	30	34	38
50	35	39	44	58	63	77
65	53	57	61	65	73	81
80	59	65	78	91	104	156
100	66	110	110	154	165	242

Nm = operating torque in Newton meter. The operating torque shall be used for selection of actuator. The shown values are the maximum required for operating a valve which has been closed for an extended period of time. For valves which will be operated often, the operating torque can be considerably lower.

(Table 15)

DN	10	15	20	25	32	40	50	65	80	100
Z	0.24	0.24	0.24	0.24	0.24	0.24	0.24	0.25	0.28	0.3
Kv	8	18	32	50	80	120	200	320	480	720

Z = resistance number

$K_v = 0,86 \times C_v$, $C_v = 1,16 \times K_v$

Welding-in NAF-Triball

Always verify the piping connecting on both ends of the valve, which have welded connections, have both the same center line and are parallel to each other. Remember that damage to the seat ring can cause leakage. Always use great care in disassembling and reassembling the valves to avoid damage to the rings from contamination. After welding, both valves and connecting pipes should be sluiced from welding debris, scale etc.

The version with long welding ends, NAF **888653/57** and NAF **888663/67** need not to be disassembled before welding. **Note that the ball must be in the open position during welding.** The length of the welding ends is such that the temperature will not damage the interior of the valve. This is on the condition that welding is done professionally and in accordance with applicable codes and standards.

NAF-Triball with short welding ends, NAF **888651/61**, must be disassembled before welding. The valve body and its seat rings must be removed as described under the headline "NAF-Triball is simple to disassemble" and replaced with a suitable spacer, such as a body of the same DN but without internal parts. Screw the end pieces together and weld the unit into the pipe. After welding, refit the complete valve body and tighten the screws to specified torque.

NAF-Triball is simple to disassemble

1. Turn the ball to the open position. Remove one of the bolts (or stud) and release the other three.
2. Remove the body section.
3. Refit the body section after the planned action is carried out and tighten the bolts (or studs).

To facilitate dismantling and handling of valves in sizes DN 65-100 these valves are equipped with a support flange for the studs which are fitted into clearance holes in the top part of the body.

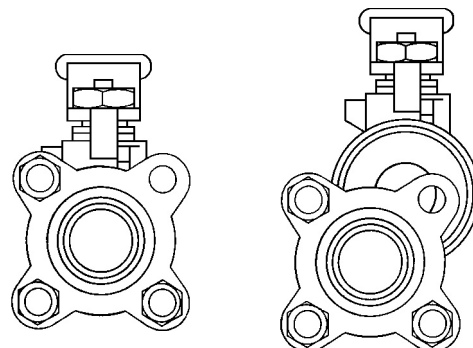

Ordering example

When ordering a valve please mention data on media, pressure and temperature.

If the valve is to be fitted with an actuator, data is also required on max. differential pressure, operating pressure (air) and whether end switches and solenoid valves are desired. Voltage and type of current should be indicated where appropriate.

Ordering of spare parts

When placing order for spare parts, specify:

- NAF-No., DN and Part No. (see the valve's identification plate)
- Quantity required
- Recommended spare part kit according to table 2, page 3

Example

NAF 888650-0015-85, Part No. 15547-0017
10 pcs spare part kit B

Accessories

Actuator

In its standard version NAF-Triball is equipped with hand lever made of stainless steel with PVC coating. The valve can also be provided with pneumatic or electric actuators for control or on-off operation.

Consult your NAF representative for further information.

Solenoid valve

See datasheet Fk. 79.17

El. limit switch

See datasheet Fk. 79.10

Other design

- Degreased for oxygen

All valve parts will be degreased before assembly.
Grease approved for oxygen is used.

Productcode: D

- Drilled vent hole in ball

A vent hole is drilled in the ball to avoid that the energy gets contained.
The valve is mounted with the arrow in the flow direction. DN10-100 3mm hole.

Productcode: H

- Stem extension

- Additional seat ring material

- Flanges to DIN 2512, Form N or DIN 2513, Form R13.

Contact NAF for further information

Product code

Example:

88 8 6 5 0 - 0 025 - 8 5
Code 1 2 3 4 5 6 7 8 9 (10)

- 1. Valve typ**
88 Ballvalve
- 2. Material**
8 1.4408/CF8M
- 3. Pressure rating**
3 PN16 (8883x2, DN80-100 flanged)
6 PN40 (8886xx, DN10-100)
- 4. Seat**
5 Soft seats i.e. PTFE
6 Metal seats i.e. Alloy 6 (DN15-100)
- 5. Connections**
0 - 9 See page 2
- 6. All except connection 54/64 (Sample valve)**
0 = Standard
Connection 54/64 only (Sample valve)
0 = Standard
A = radius 40mm
B = radius 75mm
C = radius 150mm
D = radius 250mm
Z = customer specific radius
- 7. Size**
EN version DN
0010 10
0015 15
0020 20
0025 25
0032 32
0040 40
0050 50
0065 65
0080 80
0100 100
- 8. Seat ring**
2 Alloy 6
8 MG 1241 (PTFE 75%, glass fiber 20%, graphite 5%)
- 9. Stem seal O-ring**
5 FPM
- 10. Other versions**
D Degreased for oxygen
H Drilled vent hole in ball